

DYNO[®]-MILLECO 5 *Horizontal agitator bead mill*

Dispersion and ultra-fine wet grinding
for small-scale production
practical and cost-effective



WAB – your expert for wet milling and ultra-fine dispersion



DYNO®-MILL ECO 5 – with 5-litre grinding container, contact pressure gauge and thermometer plus digital display for continuously variable milling speed.

For many decades WAB has been the undisputed specialist in dispersion and milling technology with its world-renowned **DYNO®-MILL**. The stringent requirements placed on the finished product also demand the highest standards of quality and abrasion resistance from the mill components.

WAB's extensive mill programme enables it to supply the perfect mill for both your product and your process.

The features of the DYNO®-MILL ECO 5

- Ideal for passage mode with constant efficiency and for the attainment of the narrowest possible granulate size ranges in the micron order
- The optimum configuration for every product with an extremely wide choice of materials for components coming into contact with the product – including hardened steel, stainless steel, hard chrome plated stainless steel and polyurethane
- Maximum operating safety – the basic model already complies with **CE** and ATEX (Ⓜ II 2 G cb IIB T3)
- Small process volume and optimum cooling characteristics with compulsory flow of the cooling water in the outer jacket enable processing of temperature-sensitive products
- Easy to use – the **DYNO®-MILL ECO 5** can be taken apart in just a few steps, allowing rapid change-over to a different mill configuration
- Simple operation and easy setting of operating parameters
- Consistent milling concept enables scaling-up to all production mills in the **DYNO®-MILL** type **KD** series
- Low operating and maintenance costs



*The practical small-scale production mill **DYNO®-MILL ECO 5** is used for continuous dispersion and wet grinding of low to high viscosity pumpable products in the micron order.*

Low operating and maintenance costs | thoroughly practical and cost-effective

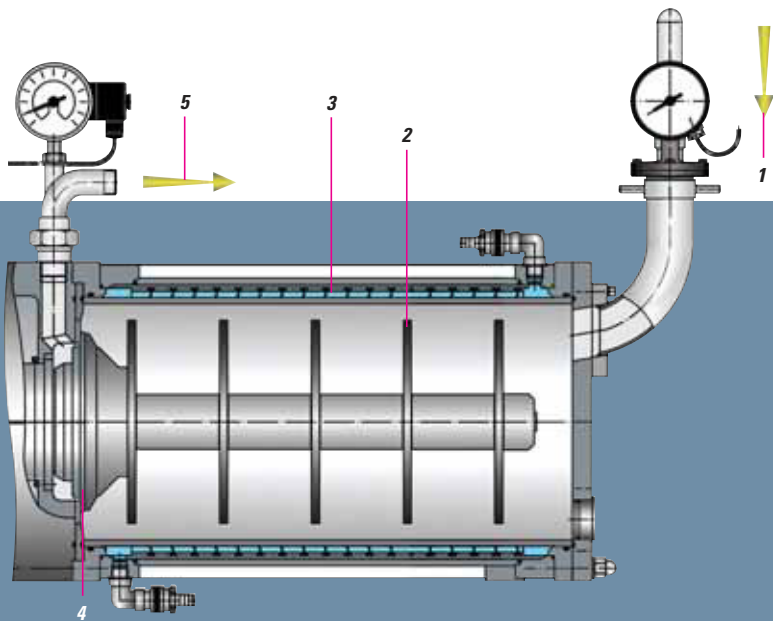

Mode of operation

- 1 Product inlet/grinding bead inlet
- 2 DYNO® agitator discs in stainless steel, hardened steel, polyurethane
- 3 Coolable grinding container with easily interchangeable grinding cylinder in hardened or stainless steel, hard chrome plated stainless steel, polyurethane
- 4 Dynamic gap separator
- 5 Product outlet

The **DYNO®-MILL ECO 5** is equipped with the traditional KD agitator discs. Easily interchangeable agitator discs, mounted on a shaft, transfer the energy required for dispersion and grinding to the grinding beads. An external pump feeds the product into the mill.

Grinding bead separation

The grinding beads are retained in the mill by means of a dynamic gap separator with rotor and stator of tungsten carbide. The gap width is adjusted with setting pieces corresponding to the grinding bead size. Grinding beads of different materials and sizes (0.5 – 2.5 mm) can be used.

Shaft seal

The shaft seal is achieved with the single acting mechanical seal developed by WAB. The compact design of this seal enables quick and easy replacement. The shaft seal is lubricated with a product-compatible rinsing liquid in a closed cycle.

High-speed maintenance and cleaning

The design of the **DYNO®-MILL ECO 5** has been carefully thought out and can be precisely adapted to suit every user's need. Operation, cleaning and opening-up for maintenance work are extremely easy. Cleaning is carried out with the minimum of solvent/detergent, product loss is minimal and switching to a different product very easy.

Scaling-up to production

The geometry of the grinding system corresponds to that of the production mills, with the result that the dispersion and grinding results obtained are highly reproducible on the larger **DYNO®-MILL** type **KD** mills.



An overview of the DYNO®-MILL ECO 5

TYPE	GRINDING CHAMBER VOLUME l	CAPACITY RANGE l/h	MILL DRIVE kW	COOLING WATER CONSUMPTION l/h	WEIGHT kg	DIMENSIONS L/W/H mm
ECO 5	5	20–200	10	800–1000	250–300	1001×797×654

Changes in design reserved. The performance data quoted is intended solely as a guide and is dependent on the product to be processed.

Top performance for your product

The best in class

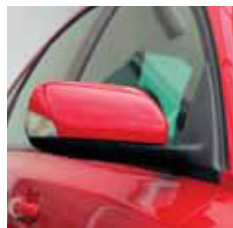
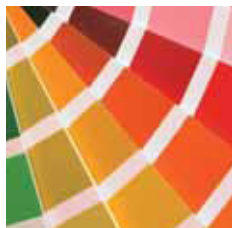

- for aqueous,
 - solvent-based
 - and contamination-free products
- in the laboratories and production areas
of countless sectors of industry

- Paints and varnishes
- Printing inks
- Coatings
- Pigments and dyes
- Automobile paints
- Food industry

- Filling and coatings
- Agrochemicals
- Paper industry
- Life sciences
- Biotechnology
- Microbiology

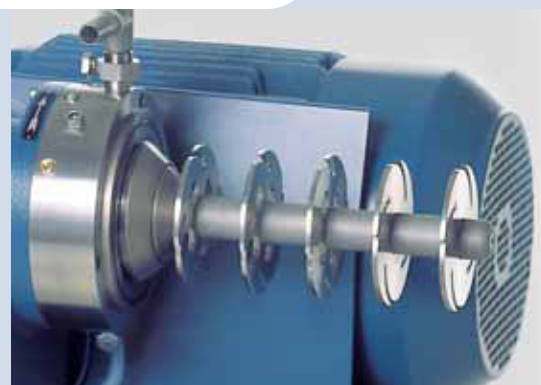

Test the performance of the future

Experience the future live in our technical centre. Test the **DYNO®-MILL ECO 5** and see its amazing performance potential for yourself. We will be pleased to arrange an appointment for you and provide assistance with any process engineering questions.

WAB global: our service and sales network

Our worldwide network with more than 40 sales and service points is available to our customers for expert advice and efficient support. It ensures a quick response and minimum production down time. In addition to the comprehensive stock at our head office, the subsidiaries and other sales and service points maintain well-stocked spare parts stores.



Willy A. Bachofen AG Maschinenfabrik
Junkermattstrasse 11
Postfach 944
CH-4132 Muttenz 1
Switzerland
Tel. +41 (0)61 6867 100
Fax +41 (0)61 6867 110
wab@wab.ch
www.wab.ch

Subsidiaries

Willy A. Bachofen GmbH
Liebigstrasse 16
D-61130 Nidderau-Heldenbergen
Tel. +49 (0)6187 93 94 0
Fax +49 (0)6187 93 94 29
wab@wab.de.com
www.wab.de.com

WAB Machinery (Shenzhen) Co., Ltd.
Block 3, Floor 1, Shunjing Building
No. 10 Industrial District, Longhua, Bao'an District
Shenzhen 518109, China
Tel. +86 (0)755 2813 5108
Fax +86 (0)755 2813 5008
wab@wab.cn.com
www.wab.cn.com

Willy A. Bachofen S.à.r.l.
3, rue Paul Henri Spaak
F-68390 Sausheim
Tel. +33 (0)389 31 17 00
Fax +33 (0)389 61 89 94
wab@wab.fr
www.wab.fr

Willy A. Bachofen UK Limited
4 Brownfields Court
Brownfields
Welwyn Garden City
Hertfordshire, AL7 1AJ, England
Tel. +44 (0)1707 327777
Fax +44 (0)1707 327778
wab@wab.uk.com
www.wab.uk.com