

DYNO[®]-MILL RL

RESEARCH LAB
agitator bead mill
for development

Efficient and reproducible
grinding and dispersion results
in the smallest scale



WAB – your expert for wet milling and ultra fine dispersion

For many decades WAB has been the undisputed specialist in dispersion and milling technology with its world renowned **DYNO®-MILL**. The stringent requirements, which the finished product has to fulfil, also demand the highest standards of quality and abrasion resistance from the mill components.

With an extensive mill program, WAB will supply the perfect mill for both your product and your process.

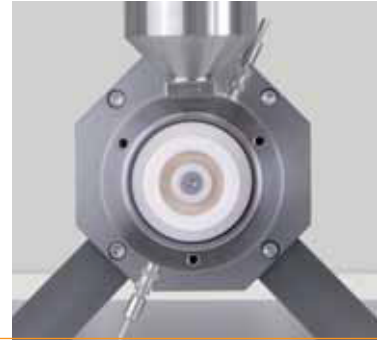

With the new **DYNO®-MILL RESEARCH LAB**, WAB has succeeded in developing a small agitator bead mill that permits

- low to high viscosity products to be ground reproducibly or produced as ultrafine dispersions in the micron- to nano-range
- small batches of product of >100 ml to be processed in a continuous passage- and circulation operation
- products to be processed metal-free using the ceramic design made of zirconium oxide/silicon carbide
- the complete, closed grinding unit to be separately and rapidly disassembled, cleaned and even sterilized
- with the unique, patented grinding principle, the DYNO®-Accelerator, best product quality with the most sharply defined ranges of fine grain particles in the range <100 nm to be obtained

- GMP-compliant design – very easy to handle
- the mill to be operated easily owing to a well-designed control system – acquisition and monitoring of operational data with a modern process control system
- quiet running in the laboratory <65 dB(A), due to a water-cooled motor



DYNO®-MILL RESEARCH LAB for rapid product development on a very small scale

The unique agitator bead mill for development work and determinations of formulations – the DYNO®-MILL RESEARCH LAB – is used for the continuous dispersion and wet fine grinding of low to high viscosity products in the micron to the nano range.

Patented grinding system – superior grinding performance even for the smallest batch sizes

Mode of operation

- 1 Feed funnel 250 ml or 500 ml
- 2 Product inlet
- 3 Sealing housing for lip seal or double acting mechanical seal
- 4 Feed screw
- 5 DYNO®-Accelerator in hardened chrome alloy or in zirconium oxide
- 6 Coolable grinding container with silicon carbide or zirconium oxide grinding cylinder
- 7 Cooling water inlet
- 8 Cooling water outlet
- 9 Grinding beads separator – flat sieve with slit widths for the use of grinding beads 0.05 – 1.0 mm
- 10 Product outlet
- 11 Grinding beads circulation

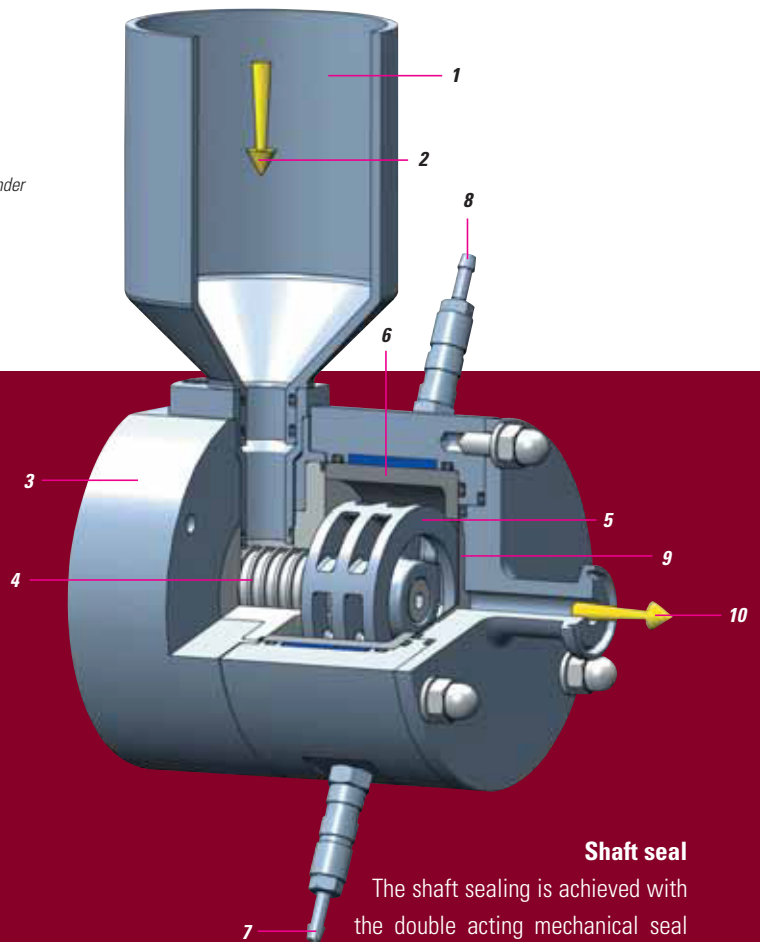

Top quality owing to high grade materials

Maximum quality requirements (metal-free grinding/dispersion), high wear resistance and long service life mean that only the best materials are used in the DYNO®-MILL RESEARCH LAB. Hardened chrome alloy or ceramic materials/zirconium oxide and silicon carbide are available for product contact parts.

Shaft seal

The shaft sealing is achieved with the double acting mechanical seal developed by WAB or with a special lip seal. The compact design of this unique mechanical seal permits easy and rapid change. A pressure sealing device with a stainless steel and circulation pump for the sealing fluid installed separately next to the mill is employed as the means to operate the double acting mechanical seal.

Grinding principle

In the DYNO®-MILL RESEARCH LAB the grinding beads are accelerated by the patented DYNO®-Accelerator and very high energy inputs are guaranteed. The grinding beads are retained in the mill by the sieve plate at the product outlet.

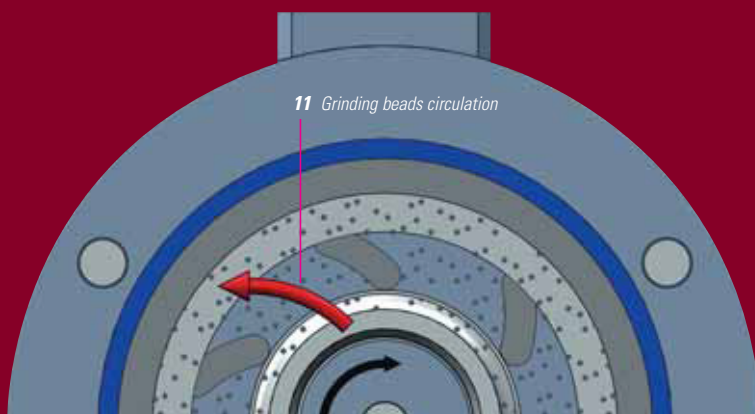

Formulation and development of optimum product quality and reproducibility | with the WAB control and validation concept

WAB provides a comprehensive control system package. The DYNO®-MILL RESEARCH LAB can be equipped with a manually operable to fully automatic control system designed to be splash- or explosion-proof in accordance with 94/9/EU (ATEX).

Pharma-compliant design – with WAB validation concept

*The qualification documents DO, IQ, OQ that are required for validation or the certificates for the process-relevant machine components such as calibration- and materials certificates are available for all DYNO®-MILLS. On request, we can also carry out the **Factory Acceptance Test** in our factory or the **Site Acceptance Test** at your production site.*

WAB CONTROL control system (IP 65)

In addition to the easily surveyed and simple operation of the mill, the WAB CONTROL control system guarantees the monitoring, acquisition and recording of all process-relevant parameters, such as:

- Agitator shaft speed (rpm)
- Initial product temperature (°C)
- Energy input (kWh)
- Link to a PC, for rapid and simple recording



WAB VIEW control system

The WAB VIEW control system for the explosion hazardous area. The design of the PLC control is modular and expandable

- Data acquisition
- Process control via product temperature or kW input
- Management of formulations
- Communications system via modem
- Link to a PC or a control system is an option



Handy and convenient to use – owing to the unique design of the mill



The assembly of the DYNO®-MILL RESEARCH LAB is well-designed and the mill can be disassembled and cleaned quickly. The uniqueness in the case of the RESEARCH LAB lies in its construction. The completely enclosed grinding chamber can be easily dismantled from the drive, so that cleaning is easy to carry out. As a result separate sterilization of the entire grinding chamber is also possible.



Filling with the grinding beads is easy to carry out by dismantling the grinding chamber and opening the front lid



Emptying the grinding beads and cleaning of the grinding chamber is easy to do when the grinding container is dismantled

Technical data DYNO®-MILL RESEARCH LAB

GRINDING CHAMBER VOLUME ml	MINIMUM BATCH VOLUME ml	MILL DRIVE kW	AGITATOR SHAFT SPEED rpm	WATER COOLING REQUIREMENT l/h	WEIGHT OF BASIC MACHINE kg	DIMENSIONS L/W/H mm
80	100	1.1	1500–6000	100–300	ca. 25	620x250x430

Subject to changes in design. The specified performances are approximate values and depend on the product to be processed.

Product development on a very small scale |

with the most up-to-date grinding technology



- for aqueous,
- solvent-based
- and contamination sensitive products

in research and development laboratories as well as in university institutes

- Paints and varnishes
- Printing inks
- Coatings
- Pigments and dyes
- Automobile paints
- Ink jet inks
- Ceramics
- Dental fillings
- Food industry

- Microelectronics, semiconductors
- Fillings
- Pharmaceuticals
- Cosmetics
- Agrochemicals
- Paper industry
- Life sciences
- Biotechnology
- Microbiology



Test the performance of the future

Experience the future live in our technical center. Test the **DYNO®-MILL RL** and see its amazing performance potential for yourself. We will be pleased to arrange an appointment for you and provide assistance with any process engineering questions.

WAB global: our service and sales network

Our worldwide network of more than 40 sales and service points is available to our customers for expert advice and efficient support. It ensures always a quick response and minimum down times. In addition to the comprehensive stock at our head office, our subsidiaries and other sales and service points maintain well-stocked spare parts stores.



Willy A. Bachofen AG Maschinenfabrik
Junkermattstrasse 11
Postfach 944
CH-4132 Muttenz 1
Switzerland
Tel. +41 (0)61 6867 100
Fax +41 (0)61 6867 110
wab@wab.ch
www.wab.ch

Subsidiaries

Willy A. Bachofen GmbH
Liebigstrasse 16
D-61130 Nidderau-Heldenbergen
Tel. +49 (0)6187 93 94 0
Fax +49 (0)6187 93 94 29
wab@wab.de.com
www.wab.de.com

WAB Machinery (Shenzhen) Co., Ltd.
Block 3, Floor 1, Shunjing Building
No. 10 Industrial District, Longhua, Bao'an District
Shenzhen 518109, China
Tel. +86 (0)755 2813 5108
Fax +86 (0)755 2813 5008
wab@wab.cn.com
www.wab.cn.com

Willy A. Bachofen S.à.r.l.
3, rue Paul Henri Spaak
F-68390 Sausheim
Tel. +33 (0)389 31 17 00
Fax +33 (0)389 61 89 94
wab@wab.fr
www.wab.fr

Willy A. Bachofen UK Limited
4 Brownfields Court
Brownfields
Welwyn Garden City
Hertfordshire, AL7 1AJ, England
Tel. +44 (0)1707 32 77 77
Fax +44 (0)1707 32 77 78
wab@wab.uk.com
www.wab.uk.com