

# DYNO<sup>®</sup>-MILL ECM *High-efficiency agitator bead mill*

Dispersion and wet grinding  
technology brought to perfection



# WAB – your expert for wet milling and ultra fine dispersion

For many decades WAB has been the undisputed specialist in dispersion and milling technology with its world renowned **DYNO®-MILL**. The stringent requirements, which the finished product has to fulfil, also demand the highest standards of quality and abrasion resistance from the mill components.

With an extensive mill program, WAB will supply the perfect mill for both your product and your process.

## Features of the DYNO®-MILL ECM High-efficiency agitator bead mill

- Patented DYNO®-Accelerators ensure powerful, hydraulic movement of the grinding beads and guarantee high and uniform energy input for products of low to high viscosity
- Ideal for passage and recirculation process with constant efficiency and achievement of the narrowest possible particle size ranges

- Guaranteed long service life as a result of using materials of high-quality (SiC, ZrO<sub>2</sub>, hardened chrome alloy)
- Low power consumption (kWh/kg product) thanks to efficient energy input
- Small process volume and ideal cooling properties permit the processing of temperature-sensitive products
- Gentle processing as a result of hydrodynamic movements
- Change of sieve cartridge without opening the mill container
  - Very easy to clean with a minimum of cleaning fluids
  - Easy to handle with low operating and maintenance costs due to the unique design of the grinding chamber
  - Mill easy to operate due to well-designed control system
  - Recording of operation data and guarantee of reproducibility with the use of the modern WAB VIEW process control system (optional)



*DYNO®-MILL ECM Poly with the modern WAB VIEW process control system*

The unique **high-efficiency agitator bead mill – the DYNO®-MILL ECM** – is used for the continuous dispersion and wet fine grinding of pumpable products with low to high viscosity in the **micron and nano range**. The DYNO®-MILL ECM provides excellent performance for very high throughputs in a circulation process but also in a passage operation.

# The best performance for your product – superior internal design



## Top quality comes from the use of high-grade materials

Maximum quality requirements (metal-free grinding/dispersion), high wear resistance and long service life mean that only the best materials are used in the DYNO®-MILL ECM. Hardened chrome alloy or also ceramic materials/zirconium oxide and silicon carbide are available for the parts that come in contact with the product.

### Mode of operation

- 1 DYNO®-Accelerators in hardened chrome alloy or in zirconium oxide
- 2 Product inlet/ grinding bead inlet
- 3 Coolable grinding container with silicon carbide grinding cylinder (optionally also in hardened stainless steel)
- 4 Separation system – sieve cartridge with slit widths for use of grinding beads 0.2–2.0 mm
- 5 Product outlet
- 6 Grinding bead circulation

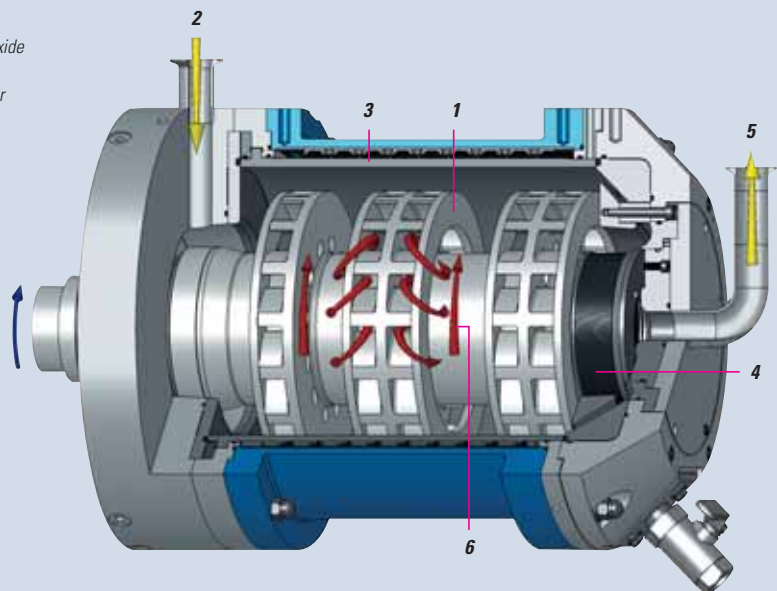
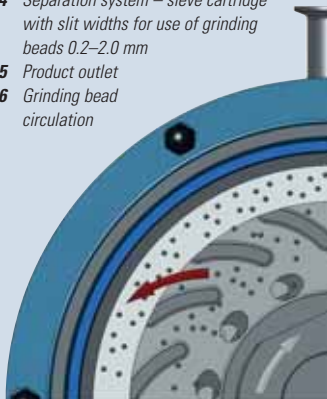

The grinding beads in the DYNO®-MILL ECM are accelerated by the patented DYNO®-Accelerators. Resulting from the design of the mill, internal grinding bead circuits are set up that guarantee narrow dwell-time spectrum combined with highest energy density. The grinding bead circuits are several times greater in intensity and velocity than the coupled motion effect exerted on the grinding beads by the stream of product in the direction of the mill exit. The grinding beads are retained in the mill by the sieve cartridge at the product outlet. The efficient cooling of the grinding cylinder made of the highly abrasion resistant silicon carbide permits the processing of temperature-sensitive products.

The choice of grinding bead quality is essential and affects the grinding or dispersing performance and the life time of the parts in contact with the product. WAB tests and investigates in its own laboratory the various, commercially available grinding beads using DYNO®-MILLS. You do not simply buy a mill from WAB, you receive professional advice about the mill and about your product.



# Low operating and maintenance costs – | simple and economical

The assembly of the DYNO®-MILL ECM is well-designed and optimally adaptable to every process. Operating, cleaning and opening the mill for servicing is very simple. The cleaning is done with the minimum solvent/cleaning fluids, the loss of product is minimal and the switch from one product to another is very easy.



## Servicing and cleaning made easy – short down times

- The sieve cartridge can be changed without opening the grinding container
- The grinding container can be opened with an easy-to-use manual removing device. The cleaning and servicing work can be done at the optimal working height.
- The movable collecting dish permits rapid changing and cleaning of the grinding beads.
- The DYNO®-Accelerators can be disassembled with a minimum of manual operations and rapid access to the shaft seal is guaranteed.

## Shaft seal

The shaft sealing is achieved with the double mechanical seal developed by WAB. The compact design of this unique mechanical seal permits easy and rapid change. The rinsing liquid installation with cooled, stainless steel container is assembled in the machine housing and is readily accessible. The pressure in the rinsing circuit is adjusted by a control valve. Before delivery the mechanical seals are always checked for leakage and quality which emphasizes the reliability of the WAB seals. In addition to simple maintenance, the mechanical seals can be sent to the factory for inspection. WAB will replace the functionally relevant components. After

inspection, this seal undergoes the WAB standard quality test. In this way our customers obtain optimal benefit and reduce the maintenance costs considerably.

## Reproducibility – WAB VIEW modern process control system

WAB provides a comprehensive control system package. The DYNO®-MILLS can be equipped with manually operable to partially automatic to fully automatic control systems.

In addition to the easily surveyed and simple operation of the mill, the WAB VIEW control system guarantees proper monitoring and recording of all process-relevant values. The design of the PLC control is modular and extensible:

- Data acquisition
- Process control via product temperature or kW input
- Automation module for passage and recirculation operation
- Visualisation systems with comprehensive management of formulations
- Communications system via modem
- Links to a PC or a control system are optionally included in our offer.



*DYNO®-MILL ECM Plus*

# Scale-up from the laboratory to production with patented DYNO<sup>®</sup>-Accelerators

For small runs of 1 litres or more and for research and development work the MULTI LAB with the DYNO<sup>®</sup>-Accelerators (0.6 litre grinding chamber volume) is the ideal laboratory mill. Other mill sizes up to the 60 litres ECM Ultra are available. Thanks to the consistent grinding design with the DYNO<sup>®</sup>-Accelerators, the scale-up from the laboratory scale up to the production mill is guaranteed.

## DYNO<sup>®</sup>-MILL MULTI LAB

The ideal laboratory mill for all grinding and dispersion tasks for continuous and discontinuous operation.



## DYNO<sup>®</sup>-MILL ECM Ultra

The ECM Ultra offers the ideal solution for maximum throughputs and maximum productivity. Even mills of this size are very easy to handle.



### The product range of the DYNO<sup>®</sup>-MILL ECM in outline

TYPE	GRINDING CHAMBER VOLUME l	CAPACITY RANGE l/h	MILL DRIVE kW	COOLING WATER CONSUMPTION l/h	WEIGHT kg	DIMENSIONS L/W/H mm
<b>MULTI LAB</b>	<b>0.6</b>	<b>5–50</b>	<b>3.3–4.0</b>	<b>400</b>	<b>100</b>	<b>680x740x580</b>
<b>ECM Pilot</b>	<b>1.5</b>	<b>10–200</b>	<b>7.5</b>	<b>800</b>	<b>380</b>	<b>1372x830x710</b>
<b>ECM Poly</b>	<b>8.2</b>	<b>100–1500</b>	<b>22.0–30.0</b>	<b>1500</b>	<b>900</b>	<b>1390x800x1680</b>
<b>ECM Pro</b>	<b>18.2</b>	<b>300–2500</b>	<b>44.0–55.0</b>	<b>2000</b>	<b>1900</b>	<b>1795x1016x1989</b>
<b>ECM Plus</b>	<b>23.3</b>	<b>400–3000</b>	<b>44.0–55.0</b>	<b>2000</b>	<b>2000</b>	<b>1903x1016x1989</b>
<b>ECM Ultra</b>	<b>60.0</b>	<b>500–6000</b>	<b>90.0–125.0</b>	<b>3500</b>	<b>3700</b>	<b>2300x1250x2120</b>

*Subject to changes in design. The characteristics shown are indicative values and are dependent on the product to be processed.*

# Highest product quality | most up-to-date grinding technology



- for aqueous,
  - solvent-based
  - and contamination sensitive products
- in countless branches of industry

- Paints and varnishes
- Printing inks
- Coatings
- Pigments and dyes
- Automobile paints
- Ink jet inks
- Ceramics
- Microelectronics, semiconductor

- Fillings
- Pharmaceuticals
- Cosmetics
- Agrochemicals
- Paper industry
- Food industry
- Life sciences
- Biotechnology



## Test the performance of the future

Experience the future live in our technical center. Test the **DYNO®-MILL ECM** and see its amazing performance potential for yourself. We will be pleased to arrange an appointment for you and provide assistance with any process engineering questions.

## WAB global: our service and sales network

Our worldwide network of more than 40 sales and service points is available to our customers for expert advice and efficient support. It ensures always a quick response and minimum down times. In addition to the comprehensive stock at our head office, our subsidiaries and other sales and service points maintain well-stocked spare parts stores.



Willy A. Bachofen AG Maschinenfabrik  
Junkermattstrasse 11  
Postfach 944  
CH-4132 Muttenz 1  
Switzerland  
Tel. +41 (0)61 6867 100  
Fax +41 (0)61 6867 110  
wab@wab.ch  
www.wab.ch

### Subsidiaries

Willy A. Bachofen GmbH  
Liebigstrasse 16  
D-61130 Nidderau-Heldenbergen  
Tel. +49 (0)6187 93 94 0  
Fax +49 (0)6187 93 94 29  
wab@wab.de.com  
www.wab.de.com

WAB Machinery (Shenzhen) Co., Ltd.  
Block 3, Floor 1, Shunjing Building  
No. 10 Industrial District, Longhua, Bao'an District  
Shenzhen 518109, China  
Tel. +86 (0) 755 2813 5108  
Fax +86 (0) 755 2813 5008  
wab@wab.cn.com  
www.wab.cn.com

Willy A. Bachofen S.à.r.l.  
3, rue Paul Henri Spaak  
F-68390 Sausheim  
Tel. +33 (0)389 31 17 00  
Fax +33 (0)389 61 89 94  
wab@wab.fr  
www.wab.fr

Willy A. Bachofen UK Limited  
4 Brownfields Court  
Brownfields  
Welwyn Garden City  
Hertfordshire, AL7 1AJ, England  
Tel. +44 (0) 1707 32 77 77  
Fax +44 (0) 1707 32 77 78  
wab@wab.uk.com  
www.wab.uk.com